

SRL-49

- process meter with bargraph
- input 0/4-20 mA
- 2 or 4 relay outputs (or OC)
- RS-485 / Modbus RTU
- option: active current output

The **SRL-49** process meter features current input with protection safeguarding the measuring resistor against damage. The measurement is visible simultaneously on the 4-decade LED display and 20-point, two-colour bargraph reflecting 0-100% of measuring range. The set threshold values are also shown on the bargraph, and the LEDs indicate when the values are exceeded. The device operates in the following modes: linear, root, square and user defined (max. 20 points). 2 or 4 relay outputs enable adjustment of the level of the measured signal. The relay output can be controlled according to one or two threshold values.

- programmable measuring range,
- programmable relay hystereses,
- programmable relay delay,
- password protected,
- programmable indication filtration,
- overload-protected current input.



Typical applications

1. Measurement of pressure in pipelines with air pressure control by means of the frequency inverter and signalling of minimum and maximum thresholds.

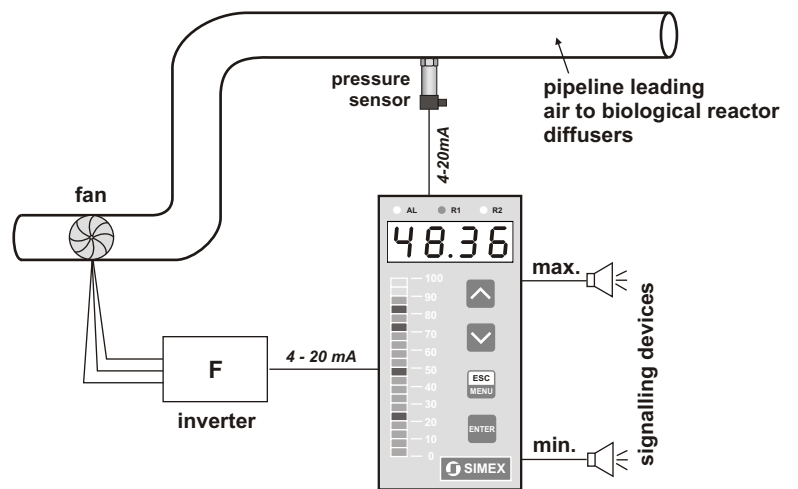

Exemplary pin assignment

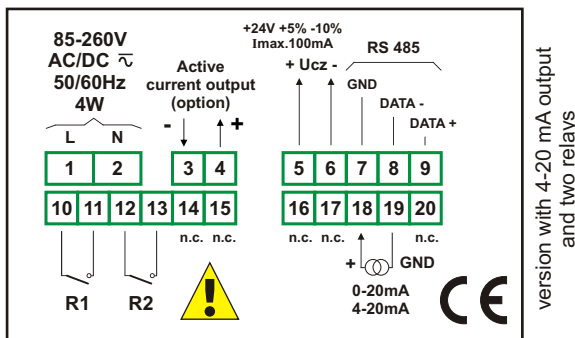

Ordering

SRL-49-11XX-1-X-XX

- options:**
01 : IP65
- power supply:**
3 : 24V - 48V AC
4 : 85V - 260V AC/DC
- type of outputs:**
1 : REL (for 2 and 4 outputs)
2 : OC (for 2 and 4 outputs)
3 : 2 x REL + current output
4 : 2 x OC + current output
- number of outputs:**
2
3
4

Technical data

Power supply: 19V + 50V DC; 16V + 35V AC or 85 + 260V AC/DC
Power consumption: for 85 + 260V AC/DC and 16V + 35V AC power supply: max. 4,5 VA; 19V + 50V DC power supply: max. 4,5 W
Display: LED, red, 4 x 9 mm high + 20-points bargraph, red-green
Input: current 0-20 mA or 4-20 mA, programmable, overload-protected, input current limited to about 40 mA
Measuring range: -999 - 9999 + decimal point
Accuracy: ± 0,25% ± one digit in the entire operation range
Outputs: 2 or 4; relays 1A/250V AC (cosφ=1) or the OC 30mA/30VDC/100mW
Transducer power supply output: 24V DC +5% -10% / max. 100 mA, stabilized, not insulated from measuring inputs
Active current output: operating range max. 0 - 24 mA (option available with 2 relays, see ordering)
Communication interface: RS 485, 8N1, 1200 bit/s + 115200 bit/s, Modbus RTU (not galvanically isolated)
Operating temperature: 0°C + +50°C
Storage temperature: -10°C + +70°C
Protection class: IP 65 (front side when an additional frame is installed); IP 40 (front side); IP 20 (case and connection clips)
Case: board
Case material: NORYL - GFN2S E1
Case dimensions: 48 x 96 x 100 mm
Panel cut-out dimensions: 43 x 90,5 mm
Installation depth: min. 102 mm
Board thickness: max. 5 mm

Contika
 Hindhøjen 82
 8382 Hinnerup
 Tel 86245066