

M680 *Infraducer*[®]

A Multi-Channel Ultra-Precision Intelligent
Fiber Optic Infrared Thermometer



- *Up to 4 channels per unit*
- *Wide temperature range: 150° to 4000°C*
- *High accuracy*
- *Fast response*
- *Broad range of applications*
- *Digital and analog outputs*

Mikron M680 *Infraducer... high accuracy,*

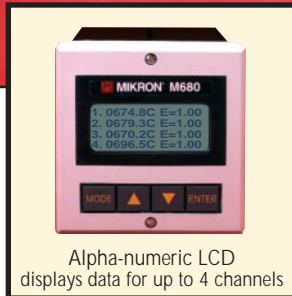

Alpha-numeric LCD displays data for up to 4 channels

Mikron M680 *Infraducer* represents a major advance in non-contact infrared temperature measurement technology. This unique

multi-channel, fiber optic infrared thermometer features exceptionally broad temperature spans from as low as 150°C up to 4000°C and selected spectral responses in the 0.65 to 1.6 micron domain. This combination of features makes the M680 the ideal instrument for an extensive range of applications requiring accurate temperature measurement at multiple locations, such as:

- Semiconductor, rapid thermal processing, CVD, PVD, Plasma etching, epitaxial reactors
- Crystal growing
- Induction heat treating
- Heat treatment and fabrication of metals
- Glass forehearth, Glass melting tank
- Vacuum metal melting

Users of the Mikron M680 can choose from 1 to 4 measurement channels and can select from a variety of lens assemblies, optical cable lengths and temperature ranges. The use of the lens

assembly and flexible fiber optic cable permits the measurement of targets which are not in direct line of sight of the detector. Other benefits include location of the sensitive electronics module at a safe distance from the process heat source, the elimination of water cooling in such applications as glass and metallurgical furnaces and the ability to measure in enclosed vessels or in nucleonic or electromagnetic environments. The multi-channel configuration of the M680 also results in cost savings over a number of single channel units.

Other features of the M680:

- Automatic calibration when fiber optic cables are replaced
- Measurement of low emissivity reflective surfaces
- Fast response; high speed 20 measurements/sec./channel
- Local front panel display of temperature and emissivity for each channel
- RS 232C bi-directional computer link
- Compact 1/4 DIN size
- Selection of up to 2 spectral bands

multi-channel fiber optic infrared thermometer

The M680 System

An M680 system is comprised of a 1/4 DIN size module for panel, bench or surface mounting, and 1 to 4 flexible, single strand, fiber optic cables with appropriate energy gathering fittings. The fiber optic cables connect directly to the rear of the electronics module with standard SMA 905 connectors.

Rear View of the M680

Connections for optional analog, output is not shown.



Fiber optic cable connectors (4 in total)

24VDC power connector

RS232C bi-directional computer communications link

The front panel of the unit has an easy to read back-lit LCD panel which displays alpha-numeric set-up data, or simultaneous temperature and emissivity for each measurement channel. Just four soft buttons facilitate local communication with the M680 for the following settings. These same settings can be initiated or read from a remote computer via the RS232C link:

Mode Selection: temperature and emissivity display per channel or set-up data.

Function Selection: emissivity, temperature units etc.

Set Temperature Range: defines the temperature range for each channel's analog output.

Manual or Auto Fiber Coefficient Setting: adjusts the calibration to match the fiber transmission coefficient of the selected fiber optic cable.

System Calibration: allows a single point calibration check of each channel.



Front View

Each M680 unit can be specified with 1 to 4 fiber optic measurement channels which allow full interchangeability of fiber cables through a built-in fiber coefficient calibration. The fiber coefficient, which compensates for variations in transmission attenuation from cable to cable, can be entered into the set-up function manually, if known, or automatically determined by the instrument when calibration source is used. Energy collection into the fiber can be via either a lens assembly or a sapphire or quartz light probe according to the needs of the application.

Temperature Ranges and Spectral Responses

Selection of temperature range is primarily dictated by the needs of the application, but may also be influenced by the desirability of a particular spectral response, which is the waveband of infrared energy to which the detector responds. Narrow wavebands at short wavelengths are less influenced by changing surface characteristics, such as oxidation. Thus a 0.65 micron spectral response is preferred over a 1.0 - 1.60 micron spectral range, if available in the same temperature range.

Four channel Models M680-4 and M681-4 can be specified with one or two different temperature ranges within the same spectral response, with each range applied to two channels. See the selection table on page 6 for the choice of temperature ranges and associated spectral responses.



Standard Lens Assembly

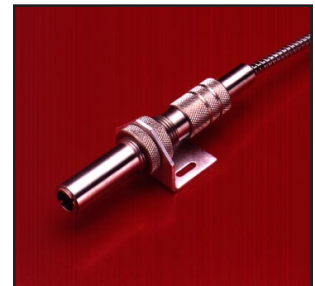

Focussable Lens Assembly

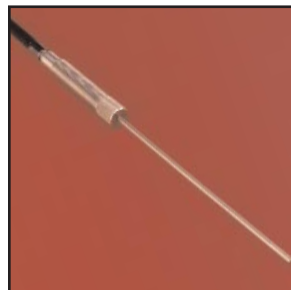

Light Probe Assembly



Mini Lens Assembly

Typical Applications

Semiconductor Wafer Processing

The manufacturing of silicon wafer semiconductors has many vacuum processes that require exacting temperature measurement of the silicon wafer, such as crystal growth, RTP, CVD, epitaxial reactors, or Etching. A sensor to provide accurate wafer temperature measurement is necessary to provide high quality and acceptable yields. The M680 with a choice of from 1 to 4 channels per unit and a selection of application specific wavelengths, fiber optic cables and lens or probe designs provides the ideal solution for both equipment manufacturers and users.

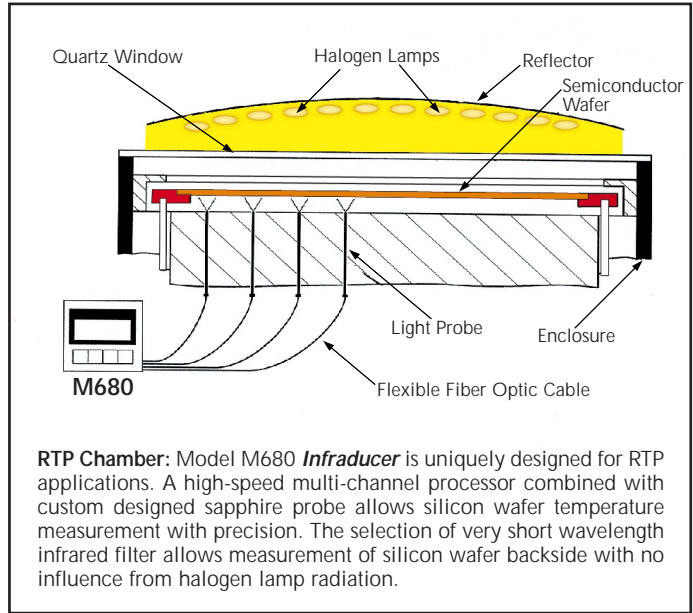

Induction Heating and Heat Treating

The use of fiber optic infrared thermometers for measurement and control of automatic induction heating systems is well established. The M680 creates the opportunity for significantly better control of this process because it is able to track temperatures through the complete heating cycle as a result of its wider temperature ranges. Short wavelength spectral responses enhance measurement accuracy by a considerable reduction in errors attributable to the changing surface emissivity of the work piece. Further advantages of the M680 lie in its ability to accurately measure shiny surfaces and to monitor several zones with one system. A typical example of such an application is piston ring hardening.

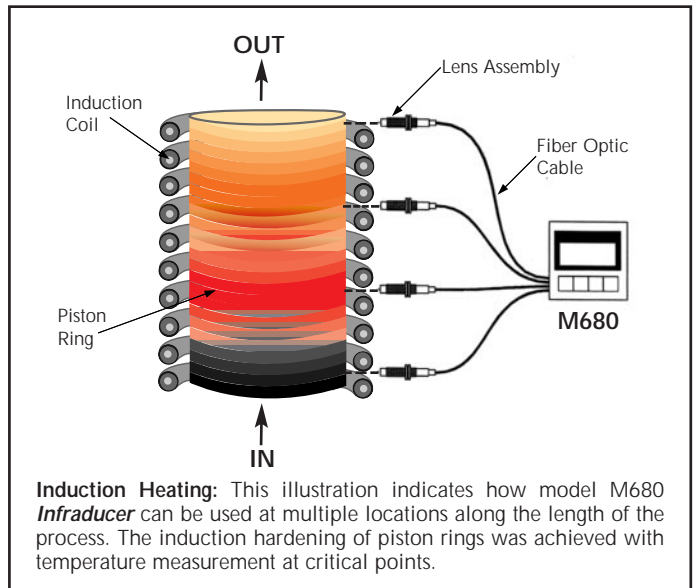

Glass Forehearth Zone Temperature

Thermocouples for these applications experience rapid deterioration in accuracy and require frequent replacement due to chemical and frictional erosion of the thermowell. Conventional infrared thermometers require water cooling to protect the sensitive electronics in the sensing head and this is often difficult and costly to maintain. The M680 lens assembly contains no electronics and can tolerate typical glass plant temperatures with either no cooling or just air cooling. The fiber optic cable allows the electronics to be mounted in a cool location.

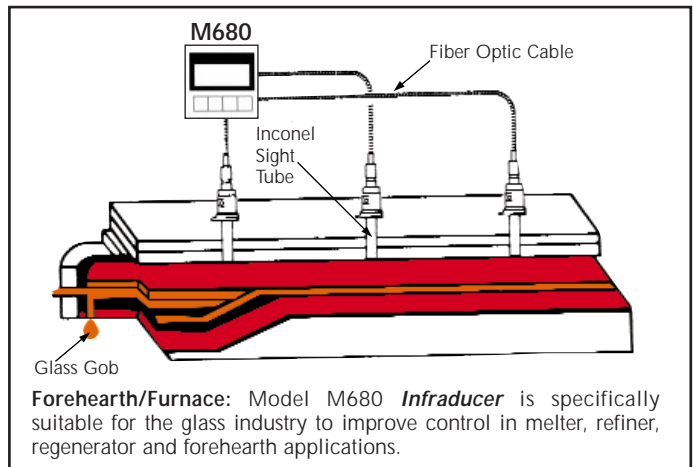

M680 Specifications

***Accuracy Standard:** $\pm 0.3\%$ of reading, $\pm 1^\circ\text{C}$

***Accuracy Optional:** $\pm 0.2\%$ of reading or 1°C , whichever is greater

Temperature Resolution: 0.1°C

****Repeatability:** 0.2°C

Temperature Uniformity Channel to Channel: $\pm 0.3^\circ\text{C}$ at calibration points, $\pm 0.5^\circ\text{C}$ elsewhere

Temperature Display: Alphanumeric with backlit LCD, 4 lines/16 characters per channel

Emissivity: 0.100 to 1.000 in 0.001 steps. Digitally set from front panel or from communications software

Temperature Range: See selection table

Spectral Response: See selection table

Channels: 1, 2, 3, or 4

Outputs: Digital: RS232C bi-directional serial interface;

Analog: Factory set or field selectable. 4-20mA, 0-20mA, 0-5V, 0-10V, 1-5V, or 2-10V all dc, linear and isolated

Response Time: Digital: 20Hz for 4 channel or 40Hz for 2 channel;

Analog: 100msec.

Load Resistance: 800 ohms max. for 4-20mA output

Power Requirements: 24VDC nominal $\pm 10\%$, 8 watts max.

Dimensions (Display & Processor): $\frac{1}{4}$ din., 200mm (8.0") deep

Enclosure: Aluminum; front panel/plastic with rubberized protective jacket

Weight: 2.0kg (4.4 lbs.)

Lens Assembly Material: All lens assemblies are machined from solid stainless steel material

Fiber Optic Cable Material: Quartz single strand fiber protected by flexible stainless steel sheath or in plastic sheathing; minimum bend radius 50mm (2")

Fiber Optic Cable Connector: SMA 905 Male both ends

Light Probe Material: Quartz or Sapphire rod with or without protection per customer specifications

Operating Ambient Temperature:

a. **Display and Processor:** 0° to 50°C
(32° to 122°F)

b. **Lens Assembly:** -90° to 315°C
(-75° to 600°F)

Lens with Air Purge Assembly: Up to 500°C (930°F) depending on amount of air flow

c. **Fiber Optic Cable:**
Stainless Steel: -90° to 310°C
(-75° to 590°F)

Plastic: -40° to 125°C (-40° to 280°F)

d. **Light Probe Assembly:**
Sapphire Tip: Up to 1800°C
Quartz Tip: Up to 1000°C

Relative Humidity: 0% to 95% non-condensing

Ambient Storage Temperature: Display and Processor, -20° to 65°C

Vibration: Lens or light probe assembly: 5g's any axis

Shock: Lens assembly; 50g's any axis

Software: The M680 offers a standard RS232C communication port for performing remote control and configuration settings. Remote functions include Emissivity, Channel ON/OFF, Degrees C/F, Fiber Transmission (automatically or manually), System Zero Calibration, and Temperature Calibration. Each function is channel addressable. The BAUD rate is 9600 and output data is in IEEE floating point format. In addition, software allows;

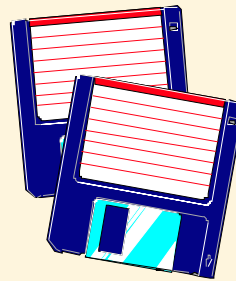

- Log data to disk in ASCII format with variable speed
- Log of temperature and time for each channel
- Display graph of 4 channels with variable speed
- Running time average of each channel output up to several seconds
- Data can be exported to popular software such as Excel, Lotus, Word, etc.

N.I.S.T. Traceable: Optional calibration certificate with 5 test points covering temperature range is available. Additional test points per customer request.

* Accuracy is stated for measurement against blackbody source having a sufficiently large aperture at specified focussed distance at ambient temperature of $23^\circ\text{C} \pm 5^\circ\text{C}$.

** Repeatability is defined for the upper 2/3 portion of temperature range.

M680 Selection Chart

PROCESSOR

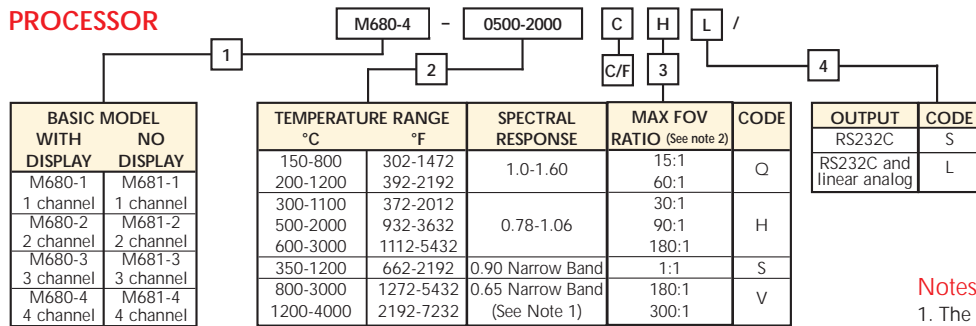

FIBER OPTICS CABLE

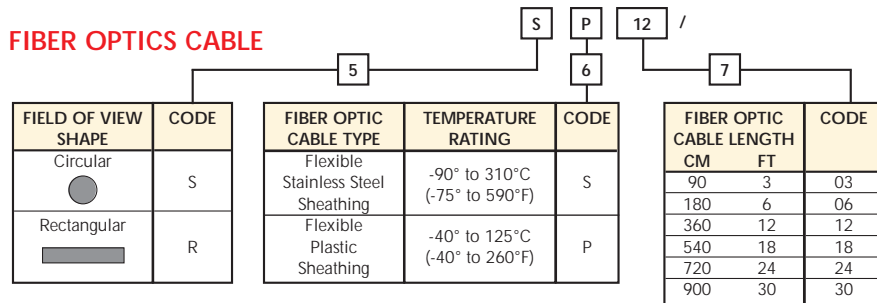

LENS ASSEMBLY

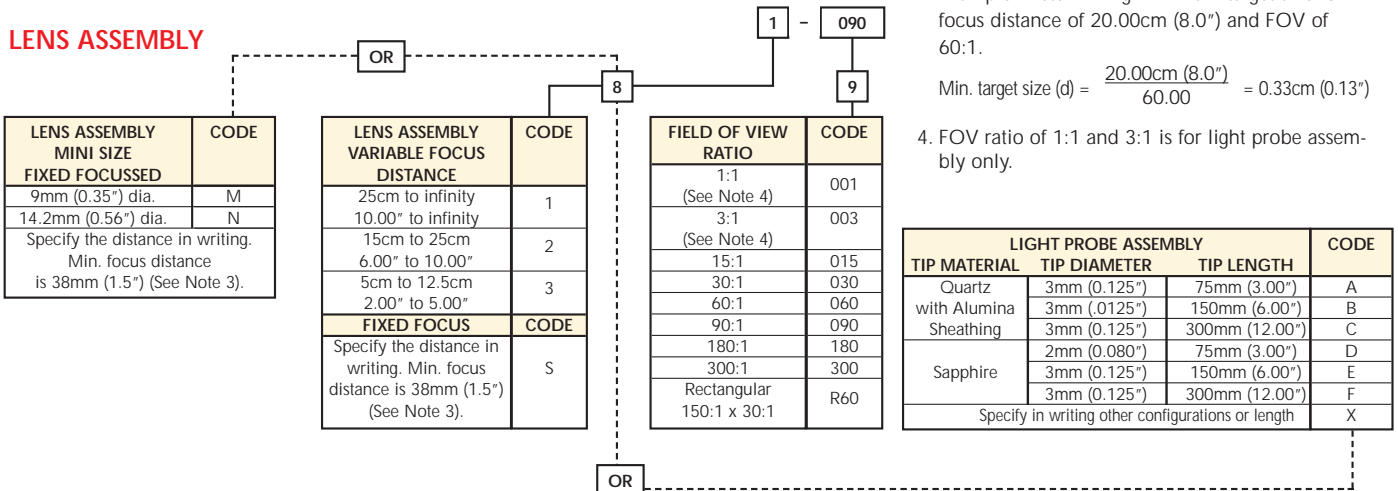

Notes

- The 0.65 micron spectral response is preferred for variable emissivity applications where the temperature range permits.
- Field of View (FOV) Ratio is defined as distance of target to lens assembly divided by minimum measurable target diameter.
Example: For FOV ratio of 90:1 the minimum target diameter at distance of 100cm (40") is 1.1cm (0.44").
- To determine the minimum target size use the following formula
$$\text{Min. target size (d)} = \frac{\text{Focussed Distance (D)}}{\text{FOV Ratio}}$$

Example: Determining minimum target size for focus distance of 20.00cm (8.0") and FOV of 60:1.
$$\text{Min. target size (d)} = \frac{20.00\text{cm (8.0")}}{60.00} = 0.33\text{cm (0.13")}$$
- FOV ratio of 1:1 and 3:1 is for light probe assembly only.

How to Select an M680 Infraducer

There are three basic components of the M680: the Processor; Fiber Optics Cable; and the Lens Assembly. The selection factors and codes for each are presented in the corresponding tables. The codes are then combined to designate the complete system.

Processor

- In the first box above the table, designate the model number desired.
- In the second box, specify the temperature range.
- In the next box, designate whether Celsius (C) or Fahrenheit (F).
- In box #3, insert the Spectral Response Code corresponding to the selected temperature range.
- The desired output is inserted in box #4.

The example indicates: M680-4-0500-2000CHL/SP12

Fiber Optics Cable

- In box #5, insert the code for the desired Field of View shape.
- In box #6, insert the code for the Fiber Optic Cable type.
- In box #7, insert the code for the desired cable length.

The example indicates: SP12

Lens or Light Probe Assembly

There are three basic types of lens assembly available: 1) the Standard Lens Assembly, either variable or fixed focus; 2) the Mini Lens Assembly; and 3) the Light Probe Assembly, available with Quartz or Sapphire rod. Selection is as follows:

- In box #8, insert the code for the specific type and size desired from the three tables.
- Insert the code for the F.O.V. ratio required in Box #9.

This ratio should be equal or less than the max FOV ratio available.

The example indicates: 1-090

Combining the three selections above to indicate the complete system, the selection is:

M680-4-0500-2000CHL/SP12/1-090

This indicates a four channel unit with a maximum temperature range of 500° to 2000°C; spectral response of 0.78 - 1.06µm and digital RS232C and analog outputs; with circular field of view; 360cm (12 ft.) long plastic sheathing fiber optic cable; variable focus lens assembly, focussable from 25cm (10 in.) to infinity and field of view ratio of 90:1.

M680 Dimensional Drawings

All dimensions are in millimeters (inches)

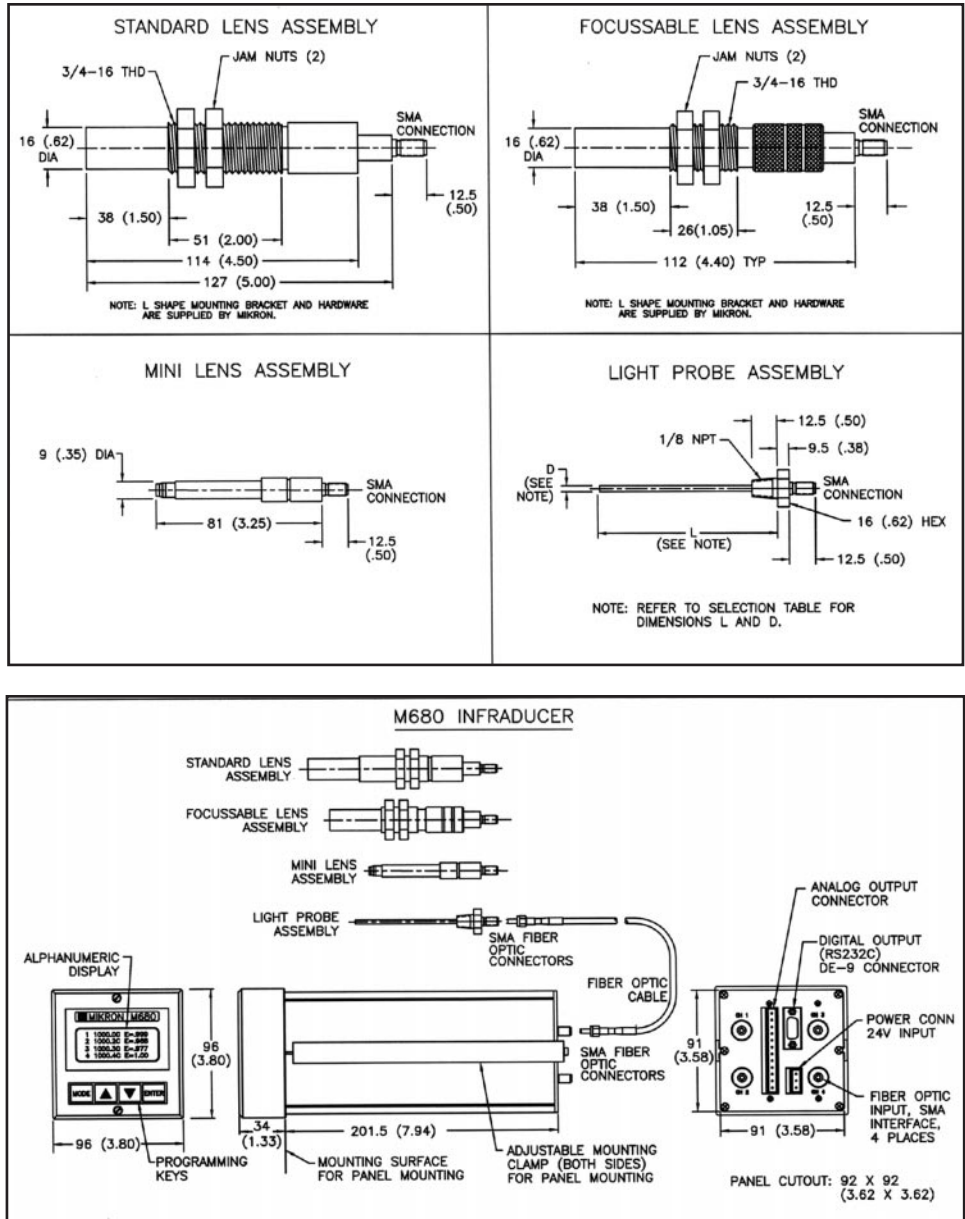

Accessories

Right Angle Viewing Attachment

Physical limitations often prohibit conventional mounting of lens assemblies. The right angle viewing attachment provides a means for rotating the physical aspect of the lens assembly by 90° while viewing the desired target. By using the right angle viewing attachment the lens assembly length of 114mm (4.5") is reduced to 30mm (1.2"). Right angle viewing is only available for standard and focussable lens assembly. Specify PN 16376-2.

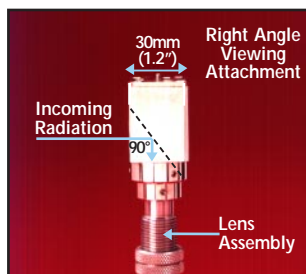

Fiber Optic Vacuum Bushing

In vacuum applications where sighting through a window is difficult or impossible, a fiber optic cable can be placed inside the vacuum up to 10⁻⁹ torr with the aid of this bushing. The bushing holds a bundle of fiber optics which is sealed for high vacuum applications. This system seals the vacuum and allows for removal of the cable on either side of the bushing without affecting the integrity of the vacuum seal. Specify PN 12506.

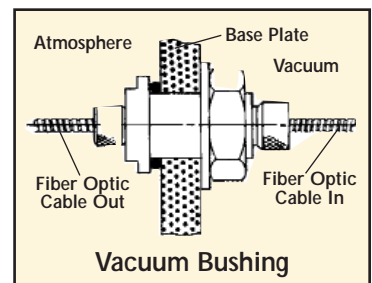

Accessories

Air Purge/Cooling Assembly

An air purge is mandatory in most industrial applications to keep the lens assembly clean for extended periods of time. The Mikron purge is designed to be effective with filtered plant air which does not need to be instrument quality. The air purge assembly will also provide cooling if the lens assembly is likely to be exposed to ambient temperatures up to 500°C (930°F). An air flow of 2.8m³/Hr. (100ft³/Hr.) is sufficient for most applications. This purge assembly is designed for standard and focussable lens assembly. The overall length of this assembly is 168mm (6.6"). The diameter of the air purge sight tube is 19mm (0.75"). Specify PN 14296-1.

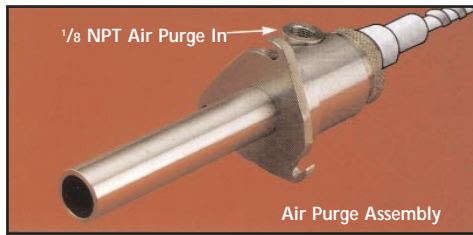

Fiber Optic Target Illuminator

Mikron offers two versions of fiber optic illuminator for precision illumination of the target areas when used in conjunction with fiber optics and lens assembly. The portable hand held illuminator with SMA connector can conveniently be taken to lens assembly location for precision refocussing or identification of target area. Batteries are rechargeable.

For AC Line Operation:

Specify PN 12110-1A for 115VAC
Specify PN 12110-2B for 220VAC
Specify PN 12110-3C for 100VAC

For Battery Operation:

Specify PN 15151-1A for 115VAC
Specify PN 15151-2B for 220VAC
Specify PN 15151-3C for 100VAC



AC Line Operation

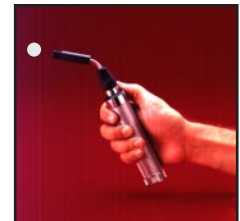

Battery Operation

Mini Air Purge Assembly

This assembly is specifically designed for a mini lens which allows a simple method of keeping the optical lens clean and cool up to the ambient of 500°C (930°F) with minimum air consumption. An air flow of 2.0m³/Hr. (70ft³/Hr.) is sufficient for most applications. This assembly also provides a steady and easy to mount platform for the installation of lens assembly at any position within process equipment. Overall length of this assembly is 140mm (5.50") and diameter of air purge sight tube is 12.7mm (0.50"). Specify PN 13254-0.

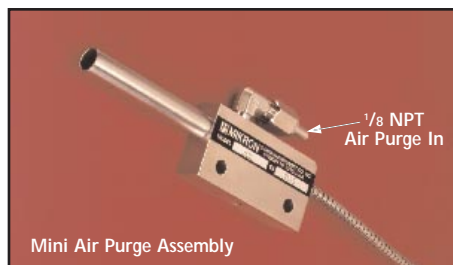

Power Supply

Power supply for M680 *Infraducer* is a low profile, sealed, switching power supply with universal AC input voltage and frequency. Maximum in-rush current of 25A protects the power supply when a momentary short circuit occurs. Specify PN 16726

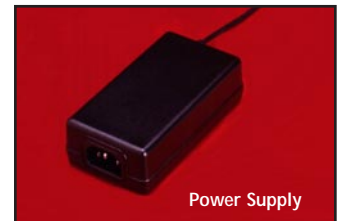

Power Supply

Input Voltage: 100 - 240VAC
Input Frequency: 47 to 63HZ
Output Voltage: 24V at 1.2 Amps
Operating Temp.: 0° to 50°C (32° to 122°F)
Dimensions: 73mm(H) x 34mm(W) x 51mm(D)
[2.87"(H) x 1.33"(W) x 2.00"(D)]
Approved By: UL, CSA and CE

Warranty

Mikron Infrared Inc. will repair or replace any parts or material found defective which are due to flaws in design or manufacture when reported in writing within one year from date of sale.

Made in U.S.A.

The M680 is designed and built by Mikron, the leading innovator in infrared thermometry. Manufacturing facility is located in Oakland, New Jersey.

Mikron reserves the right to change specifications to reflect the latest changes in technology and improvements at any time without notice. These changes will be reflected in subsequent editions of our literature when warranted.



MIKRON®

MIKRON INFRARED INC., 16 Thornton Road, Oakland, NJ 07436 U.S.A.

Tel. 1-800-631-0176 or 1-201-405-0900

Web Site: www.mikroninfrared.com

FAX: 1-201-405-0090

Catalog M680 Rev. 1.1 050803 Printed in U.S.A.



ISO 9001