

IS 5-LO · IGA 5-LO

Highly accurate, completely digital, very fast

**Stationary, digital pyrometers with fibre optic for
non-contact temperature measurement between 300°C and 3000°C**

- ◆ Temperature ranges between 300 and 3000°C
- ◆ High accuracy
- ◆ Wide temperature ranges
- ◆ Small spot sizes, min 0.45 mm
- ◆ Laser targeting light
- ◆ Analog output 0 ... 20 mA or 4 ... 20 mA
- ◆ Digital interface RS232 or RS485
- ◆ Integrated maximum value storage
- ◆ Bus control (RS485)
- ◆ Fibre optic and optical head withstand up to 250°C
- ◆ Rugged mono fibre optic (max. length up to 30 m)



Infratherm IS 5-LO and *IGA 5-LO* are fully digital pyrometers with fibre optic for non-contact temperature measurement. They are specially designed for applications under rough conditions. As the fibre and optical head do not contain electronic parts, they may be used in areas with high ambient temperatures (up to 250°C) without cooling or in areas where strong electromagnetic interferences can influence a correct measurement. The pyrometer can be adapted perfectly to an application by selection of one of the different optical heads.

These optical heads achieve smallest spot sizes. With the very short response time of < 2 ms the pyrometer can even measure fastest heating processes. The main parameters such as emissivity and response time can be set in the instrument directly. These parameters as well as the additional parameters such as sub range, maximum value storage, baud rate and address can be adjusted via PC or portable parametrizing device HT 6000 or digital indicator DA 6000-N. The Software *InfraWin* is a part of the standard delivery.

Typical applications:

- Induction heating
- Welding
- Casting
- Forging
- Annealing
- Sintering
- Rolling mill
- Rotary kilns
- Pouring stream

Technical data

	IS 5-LO	IGA 5-LO
Temperature ranges:	MB 20: 600 ... 2000°C MB 25: 800 ... 2500°C MB 30: 1000 ... 3000°C	MB 13: 300 ... 1300°C MB 18: 350 ... 1800°C MB 25: 400 ... 2500°C MB 25: 400 ... 2500°C
Subrange:	any range adjustable within the temperature range, minimum span 51°C	
IR-Detektor:	Si-photoelement (ident letter S)	InGaAs-photoelement (ident letter GA)
Spectral range:	0.8 ... 1.1 µm	1.45 ... 1.8 µm
Analog output:	0 ... 20 mA or 4 ... 20 mA, switchable, linear in temperature, load independent DC	
Max load:	500 Ω	
Accuracy:	< 1500°C: 0.3% of reading in °C + 1°C > 1500°C: 0.5% of reading in °C	
Resolution:	< 1°C	
Repeatability:	0.1% of reading in °C + 1°C	
Temp. dependence:	0.2°C per °C deviation from 23°C	
Response time t_{90} :	≤ 2 ms, adjustable up to 10 s	
Emissivity:	0.2 ... 1.00, adjustable	
Power supply:	24 V DC ± 25%, ripple max. 50 mV	
Power consumption:	max. 2.5 W (with active pilot light)	
Interface:	RS232 or RS485 addressable, half-duplex, baud rate up to 19.2 kBd	
Sighting system:	laser targeting light	
Parameters:	adjustable at the instrument: emissivity, response time, offline/online, output 0 or 4 ... 20 mA, laser targeting light additionally adjustable via interface: measuring subrange, clear time or external clearing of maximum value storage, address, baud rate; measured value and internal temperature only display.	
Maximum value storage:	single or double storage: clearing by preset time, external contact, via interface or automatically with the next measuring object	
Isolation:	power supply and digital and analog output are galvanically isolated	
Safety system:	IP65 (according to DIN 40 050)	
Connection:	12-pin plug	
Ambient temperature:	0 ... +70°C at the converter housing	
Storage temperature:	-20 ... +70°C	
Housing:	stainless steel, 102 mm x 49.5 mm (L x D without plug)	
Weight:	0.55 kg	
CE-label:	according to EU directives about electromagnetic immunity	

Option: IS 5-LO-C and IGA 5-LO-C, special versions with built-in PID-controller

The pyrometers *Infratherm* IS 5-LO and IGA 5-LO can be delivered with an built-in PID controller called IS 5-LO-C and IGA 5-LO-C. These instruments enable automatic controlling and monitoring of processes. The controller compares the actual (measured) temperature with the target value temperature and sends out a control signal. This signal can be used directly to control machines (e. g. induction heating machines). It is a very fast controller which updates the signal with the pyrometer's very short response time of less than 2 ms. The controller can be activated and deactivated and its parameters can be adjusted via interface and PC or portable parametrizing device HT 6000 or digital display DA 6000-N. Please ask for additional datasheets.

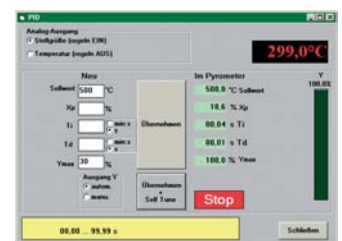

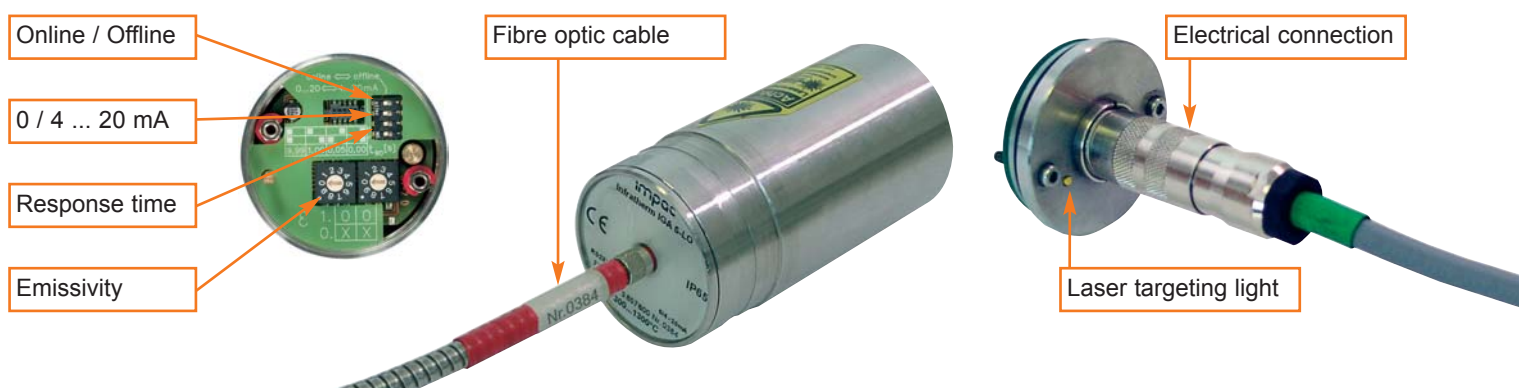

Details



Optical head

Depending on the application the instrument will be delivered with a small (type I) or a big (type II) optical head. The optics are adjusted to one of the measuring distances mentioned in the table. The distance is measured from the front of the window to the target surface. The mentioned spot size will be achieved in exactly this distance (other distances on request).

Optical head	Measuring distance a [mm]	Spot size M [mm]	Aperture D [mm]
Type I 	120	1.2	7
	260	2.6	7
	700	7.2	7
Type II 	87	0.45	17
	200	0.8	17
	600	2.7	15
	4500	22	15

Fibre optic

The radiation, coming in through the optical head, is transported via the lens system into the mono glass fibre with flexible stainless steel protection tube where it is transmitted along to the converter. As the optical head contains only the lens system and the sensor and the electronics are located in the converter box, fibre and optical head can withstand ambient temperatures up to 250°C without cooling.

Monofibre optic in stainless steel, flexible protection tube with standardised FSMA-plugs.

Length: 2.5 m, scope of delivery; 5 m, 7.5 m, 10 m, 15 m, 30 m on request
 Color mark at the fibre: red
 Ambient temperature max. 250°C (instrument's side with color mark max 125°C)
 Minimum bending radius: 50 mm for short time, 120 mm permanently

Dimensions

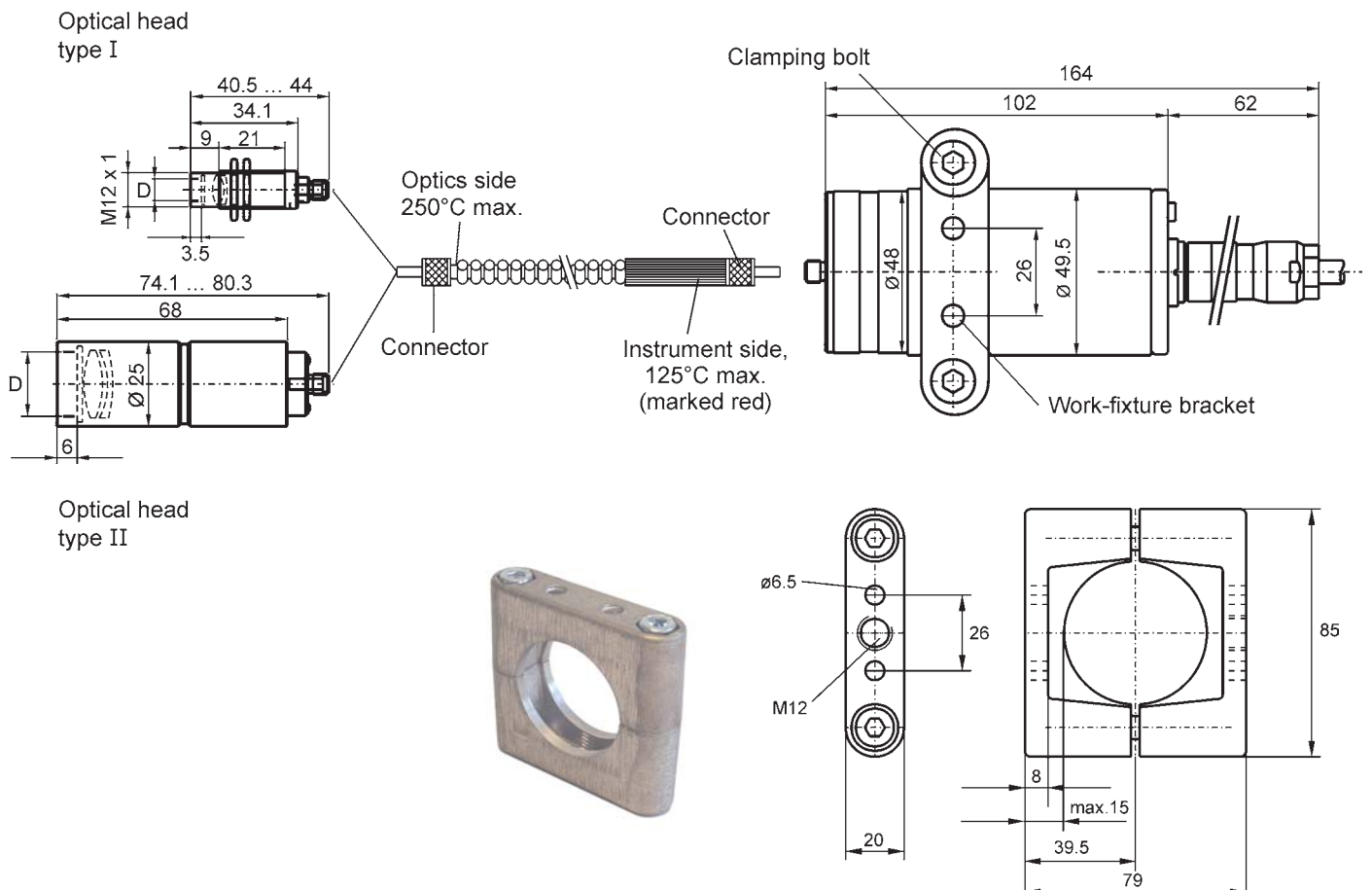

Reference numbers

Type	Temp. range	Interface		Type	Temp. range	Interface	
		RS232	RS485			RS232	RS485
IS 5-LO	MB 20: 600 ... 2000°C	3 857 750	3 857 760	IGA 5-LO	MB 13: 300 ... 1300°C	3 857 600	3 857 610
	MB 25: 800 ... 2500°C	3 857 550	3 857 560		MB 18: 350 ... 1800°C	3 857 650	3 857 660
	MB 30: 1000 ... 3000°C	3 857 770	3 857 780		MB 25: 400 ... 2500°C	3 857 700	3 857 710
			MB 30: 500 ... 3000°C		3 857 720	3 857 730	

Scope of delivery: Converter, optical head I or II, optical fibre 2.5 m, mounting unit for converter, works certificate, PC software *InfraWin*. **A connection cable is not included in scope of delivery, it has to be ordered separately!**

Ordering details: To process your order as fast as possible, please give us the following data:

- Instrument with reference number (e.g. IGA 5-LO, 3 857 600)
- Optical head's design (I or II) and the desired measuring distance (e.g. optical head I, a = 120 mm)
- Length of optical fibre (if it's not the standard length of 2.5 m)
- Connection cable (e.g. 5 m length 3 820 330)



Accessories:

3 820 330	connection cable, length 5 m, straight connector	3 852 540	Power supply NG 0D for carrier rail mounting (85 ... 265 V AC ⇒ 24 V DC, 600 mA)
3 820 500	connection cable, length 10 m, straight connector	3 852 550	Power supply NG 2D, with 2 limit switches (85 ... 265 V AC ⇒ 24 V DC, 600 mA)
3 820 510	connection cable, length 15 m, straight connector	3 852 180	Power supply NG DC (85 ... 265 V AC ⇒ 24 V DC, 600 mA)
3 820 810	connection cable, length 20 m, straight connector	3 890 640	LED digital display DA 4000-N
3 820 820	connection cable, length 25 m, straight connector	3 890 650	LED-display DA 4000 with 2 limit switches
3 820 520	connection cable, length 30 m, straight connector	3 890 560	LED digital display DA 6000-N: with possibility for pyrometer parameter settings for digital INFRATHERM pyrometers; RS232 interface
3 820 740	connection cable, length 5 m, straight connector, temperature resistant up to 200°C	3 890 570	LED-display DA 6000-N; RS485-interface
3 834 370	Mounting support for optical head I (fixed)	3 890 660	Front cover (IP65) for LED-displays
3 834 380	Mounting support for optical head I (adjustable)	3 826 500	HT 6000, portable parametrizing device
3 834 230	Adjustable mounting support for optical head II		
3 834 050	Ball and socket mounting with clamp for optical head I or II		
3 835 170	Air purge unit, stainless steel, for optical head I		
3 835 180	Air purge unit, stainless steel, for optical head II		

Overviews Accessories



Digital indicators



Portable parametrizing device HT 6000



Air purge unit for optical head II



Adjustable mounting support for optical head II



Power supply NG 0D



Power supply NG 2D



Air purge unit for optical head I



Fixed and adjustable mounting support for optical head I

IMPAC Infrared GmbH
Temperature Measurement

Contika
Hindhøj 82
8382 Hinnerup
Tel 8624 5066

