



Perceptive Colour Recognition Sensor

WLCS-TCL-255

- 255 colour memory
- Perceptive colour sensor system
- PC programmable via RS232 / USB
- Fibre optic cable with focus lenses
- Detect and allocate colours like the human eye

Principal features:

- Up to 255 colour memory
- RS232/ USB interface
- Bright white light LED, 1 W
- Perceptive tolerance adjustment using ΔE
- L*a*b / L*u*v / DIN99 transformation
- Switchable to LED-detection
- Several teach functions (via PC or external)
- Various evaluation algorithms can be activated
- FASOP fibre optic cable and focus lenses adaptable
- Sturdy aluminium housing
- Switching frequency up to **15 kHz**
- TC-Color View software
- True colour detection
- Calibration tools

Typical applications:

- Quality management
- Reading and evaluating of R G B colour values
- Detection of colour rings on metal- and plastic cases
- Detection of colour print marks in printing industry
- Colour detection and sorting of tins
- Colour and grey scale detection
- Browning degree of baked goods
- Packaging control
- Colour selection applications (z.B. O-ring seals, closings, crown caps, labels,...)
- Automotive industry (car body panels)
- LED-detection (colour and intensity)

Dimensions

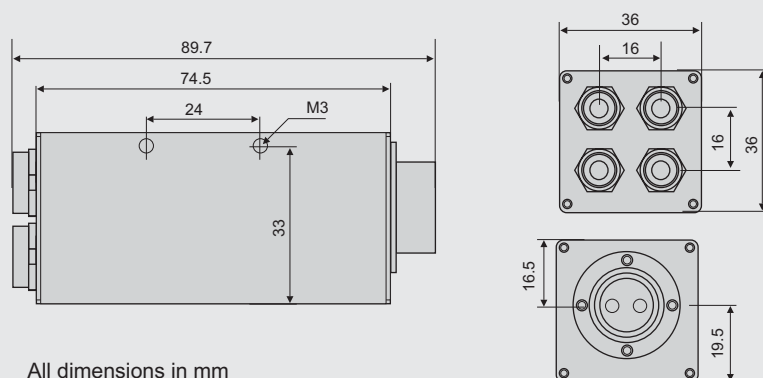

Function

Through a fibre optic cable a modulated bright white light LED projects a white light spot onto a surface to be checked. Part of the light that is reflected from the target is directed through the fibre optic cable onto a perceptive True-Colour-sensitive detector element. The received light is separated to RGB and transferred into XYZ, L*a*b or L*u*v.

The colour sensor can be parameterized (via RS232 or USB) under Windows® with the TC-COLOR View software. Up to 255 colours can be stored in the sensor. If one of the Teached-In colours is detected, results will be shown at the digital outputs OUT1 to OUT8 of the 8-pin connector.

Ordering information

Product	Part No.
Colour recognition sensor WLCS-TCL-255 (TC-Color View software included)	10233135
Connection cable	
Power supply, length 2 m	11233136
8-pin, Binder / open end	
connection to SPC, length 2 m	11233137
8-pin, Binder / open end	
RS232-cable, length 2 m	11233138
4-pin, Binder / Sub-D 9-pin	
USB-cable, length 2 m	11233139
4-pin, Binder / USB	

Technical data

Electrical data	Supply voltage	9-26 VDC
	Current consumption	typ. 500 mA
	Interfaces	RS232, USB2.0
	Colour memory	up to 255 colours
	Signal amplification	1, 5, 25, 100
	A/D conversion	12 Bit per colour channel
	Switching frequency	up to 15 kHz (> 90 µs)
Measuring value specification	Colour resolution	(L*a*b - mode) $\Delta E_{Lab} \leq 1$
	Relative accuracy at const. ambient conditions	(L*a*b - mode) $\Delta E_{Lab} \leq 1$
	Colour spaces	XYZ, L*a*b, L*u*v, DIN 99
Light source	White light LED	1 W, colour temperature 5500 K
	Brightness	adjustable, can be switched of for self-shining objects
Receiver	3-range color photo diode	Type MTCSI
	Sensitivity	0-8 µW (red channel, 600 nm)
Outputs	OUT 0 to OUT 8	open collector max. 500 mA, up to 50 V
	Interfaces	RS232, max. 115 kBit/s USB 2.0
	Trigger output	1x trigger output for external light source or for synchronisation with additional sensors
	Control input	2x for trigger and synchronization purposes
Data on ambient conditions	Operating temperature	0°C to +50°C
	Ambient light comp.	dynamic, can be switched of for self-shining objects
	Protection	IP65
Housing	Aluminium	blue anodized
	Weight	approx. 150 g

Connections

SB2

Pin	Function
1 white	OUT1
2 brown	OUT2
3 green	OUT3
4 yellow	OUT4
5 grey	OUT5
6 pink	OUT6
7 blue	OUT7
8 red	OUT0

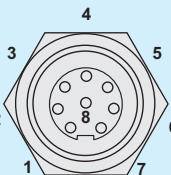
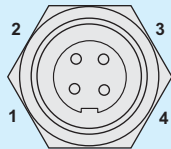

Power supply
Trigger and CLK_OUT

Switching outputs

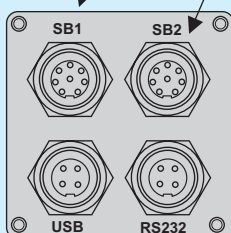

SB1

Pin	Function	Description
1 white	N.C.	
2 brown	N.C.	
3 green	TRG1	INPUT trigger signal for external. synchron. purposes
4 yellow	TRG0	INPUT for updating the sensor outputs (rising edge) in „EXTERN“ mode INPUT for trigger controlled color sequence in „TRIGG.SEQU.“ mode (rising edge) INPUT for starting timed colour sequence in „TIMED.SEQU.“ mode (rising edge) INPUT for external triggered Teach-In in „EXT. TEACH“ mode (rising edge)
5 grey	CLK_OUT	OUTPUT signal for synchronization of an additional external light source or an additional sensor
6 pink	N.C.	
7 blue	GND	Ground INPUT
8 red	(+) Vcc	Supply voltage (+9 to 26 V)

RS232

Pin	Function	Pin SUB-D (PC)
1	GND	5
2	TxD	2
3	RxD	3
4	N.C.	

USB

Pin	Function	Standard cable col.
1	GND	black
2	VBUS	red
3	D-	white
4	D+	green

© Eltrotec 09/06 Technische Änderungen vorbehalten, ohne Gewähr ELT/WLCS/WLCS_TCL_e4