

NYHED

farve sensorer



colorCONTROL oversigt



Applikationer



colorCONTROL – Software



colorCONTROL sensorer

- alle farver kan måles
 - „True Color“ funktion
 - 1-1200 mm distance
 - $\Delta E \leq 1$ opløsning
 - Teach In & software
 - Fiber optik- / refleks optik
 - PNP/NPN/RS 232/485 analog-, USB-, Profibus-interfaces
 - Gloss detektion
 - Grå / hvid detektion
 - Op til 255 farve hukommelse
-
- kontrast mark detektion DCF

Specialist for:

- alle farver, intensitet, ikke farve detektion
- alle overflade strukturer
- blanke og matte overflader, transparente materialer



Perceptive Compact Color Recognition Sensor

colorCONTROL LT1

- 255 color memory
- Teach-In (3 colors)
- PC programmable via RS232
- Fibre optic cable with focus lenses

Principal features:

- Color memory:
3 colors (Teach-In)
255 colors (software)
- RS232
- Bright white light LED
- Perceptive tolerance adjustment using ΔE
- L^*a^*b / L^*u^*v / DIN99 transformation
- Switchable to LED-detection
- Several teach functions (Teach-In / PC / external)
- Various evaluation algorithms can be activated
- Color grouping
- FASOP fibre optic cable and focus lenses adaptable
- Sturdy aluminium housing
- Switching frequency up to **15 kHz**
- colorCONTROL LT software

Typical applications:

- Detection of color rings on metal- and plastic cases
- Reading and evaluating of R G B color values
- Detection of color print marks in printing industry
- Color and grey scale detection
- Color variation control
- Color selection applications (e.g. O-ring seals, closings, crown cap, labels,...)
- Automotive industry (interieur parts)
- LED-detection (color and intensity)

Dimensions

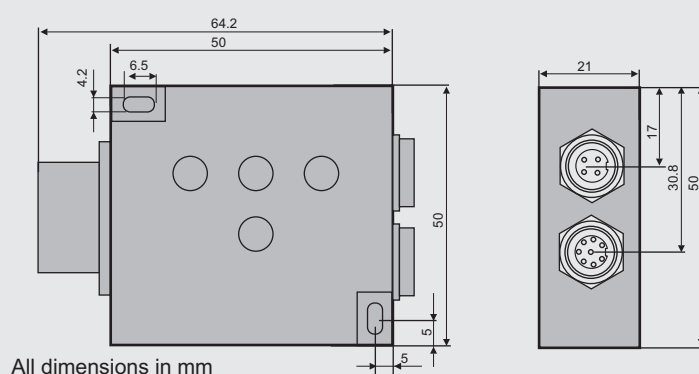

Function

Through a fibre optic cable a modulated bright white light LED projects a white light spot onto a surface to be checked. Part of the light that is reflected from the target is directed through the fibre optic cable onto a perceptive True-Color-sensitive detector element. The received light is separated to RGB and transferred into XYZ, L^*a^*b or L^*u^*v .

The color sensor can be parameterized via RS232 under Windows® with the colorCONTROL LT software. Up to 255 colors can be stored in the sensor. If one of the Teached-In colors is detected, results will be shown at the digital outputs CH1 to CH3 of the 8-pin connector.

Ordering information

Product	Part No.
colorCONTROL LT1 (colorCONTROL LT software included)	10233479
Connection cable	
Connection SB1, length 2 m 8-pin, Binder / open end	11233136
RS232-cable, length 2 m 4-pin, Binder / Sub-D 9-pin	11233138

Technical Data

Electrical data	Supply voltage	9-26 VDC
	Current consumption	typ. 100 mA
	Interfaces	RS232
	Color memory	up to 255 colors with all parameters (Software)
	Signal amplification	1, 5, 25, 100
	A/D conversion	12 Bit per color channel
Measuring value	Switching frequency	up to 15 kHz (> 90 µs)
	Target distance	typ. 1-15 mm (with optical lenses up to 200 mm)
	Color resolution	(L*a*b - mode) $\Delta E_{Lab} \leq 1$
	Relative accuracy at const. ambient conditions	(L*a*b - mode) $\Delta E_{Lab} \leq 1$
	Color spaces	XYZ, L*a*b, L*u*v, DIN 99
Light source	White light LED	1 W, can be switched of for self-shining objects
Receiver	3-range color photo diode	Type MTCSi
Outputs	Digital outputs	CH1-CH3, Push-Pull
	Interfaces	RS232, max. 115 kBit/s Parameter, Color values, Teach-In
	Trigger output	1x trigger output for external light source or for synchronisation with additional sensors
Input	Control input	2x for trigger and synchronization purposes
Data on ambient conditions	Operating temperature	-10°C to +55°C
	Ambient light comp.	dynamic, can be switched of for self-shining objects
	Protection	IP54
Housing	Aluminium	black anodized
	Weight	approx. 80 g

Short Instruction

Teach colors

- 1 Press SET -button = Setting mode
- 2 Position color and press channel button (eg. CH1) for 2 seconds
- 3 SET- button turns off shortly after 2 sec
- 4 Repeat step 2 and 3 for CH2 and CH3
- 5 Press SET - button to quit the setting mode = SET - button turns off

Tolerance setting

- 1 Press SET -button = Setting mode
- 2 Tolerance setting (channel1) by pressing the CH1 button (blinking frequency indicates the tolerance level)
- 3 Tolerance setting (channel2) by pressing the CH2 button
- 4 Tolerance setting (channel3) by pressing the CH3 button
- 5 Press SET -button to store the tolerance and quit the setting mode.
- 6 SET button turns off after 2 sec.
Blinking frequency:
 - fast (small tolerance)
 - middle (middle tolerance)
 - slow (large tolerance)

Delete color and tolerances

Press SET -button for 2 sec.

Light of the channel button indicates the current switching output

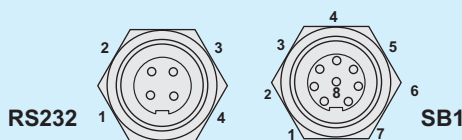

Connections

RS232

Pin	Signal	Pin SUB-D (PC)
1	GND	5
2	TxD	2
3	RxD	3
4	N.C.	do not use

Parameter: 9.600-115.200 baud, Data 8, Parity non, Stop 1

SB1

Pin	Function	Description
1 white	CH1	Output 1
2 brown	CH2	Output 2
3 green	TRG1	INPUT trigger signal for external synchronisation purposes
4 yellow	TRG0	INPUT for updating the sensor outputs (rising edge) in „EXTERN“ mode INPUT for trigger controlled color sequence in „TRIGG.SEQU.“ mode (rising edge) INPUT for starting timed color sequence in „TIMED.SEQU.“ mode (rising edge) INPUT for external triggered Teach-In in „EXT. TEACH“ mode (rising edge)
5 grey	CLK_OUT	OUTPUT signal for synchronization of an additional external light source or sensor
6 pink	CH3	Output 3
7 blue	GND	Ground INPUT
8 red	(+) Vcc	Supply voltage (+9 to 26 V)

© Eltrotec 10/07 (We reserve the right to make changes in the interest of technical progress) ELT/colorcontrol/1.1.14



Perceptive Color Recognition Sensor

colorCONTROL LT2

- 255 color memory
- Perceptive color sensor system
- PC programmable via RS232 / USB
- Fibre optic cable with focus lenses
- Detect and allocate colors like the human eye

Principal features:

- Up to 255 color memory
- RS232/ USB interface
- Bright white light LED, 1 W
- Perceptive tolerance adjustment using ΔE
- L^*a^*b / L^*u^*v / DIN99 transformation
- Calibration tools
- Switchable to LED-detection
- Several teach functions (via PC or external)
- Various evaluation algorithms can be activated
- Color grouping
- FASOP fibre optic cable and focus lenses adaptable
- Sturdy aluminium housing
- colorCONTROL LT software
- Switching frequency up to **15 kHz**

Typical applications:

- Quality management
- Reading and evaluating of R G B color values
- Detection of color rings on metal- and plastic cases
- Detection of colour print marks in printing industry
- Color detection and sorting of tins
- Color and grey scale detection
- Browning degree of baked goods
- Packaging control
- Color selection applications (z.B. O-ring seals, closings, crown caps, labels,...)
- Automotive industry (car body panels)
- LED-detection (color and intensity)

Dimensions

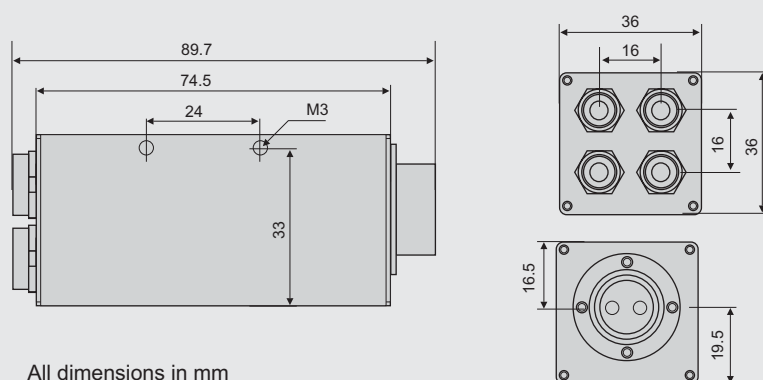

Function

Through a fibre optic cable a modulated bright white light LED projects a white light spot onto a surface to be checked. Part of the light that is reflected from the target is directed through the fibre optic cable onto a perceptive True-Color-sensitive detector element. The received light is separated to RGB and transferred into XYZ, L^*a^*b or L^*u^*v . The color sensor can be parameterized (via RS232 or USB) under Windows® with the colorCONTROL LT software. Up to 255 colors can be stored in the sensor. If one of the Teached-In colors is detected, results will be shown at the digital outputs OUT1 to OUT8 of the 8-pin connector.

Ordering information

Product	Part No.
colorCONTROL LT2 (colorCONTROL LT software included)	10233478
Connection cable Power supply, length 2 m 8-pin, Binder / open end	11233136
connection to SPC, length 2 m 8-pin, Binder / open end	11233137
RS232-cable, length 2 m 4-pin, Binder / Sub-D 9-pin	11233138
USB-cable, length 2 m 4-pin, Binder / USB	11233139



Perceptive Two-channel Color Recognition Sensor

colorCONTROL LT3

- 255 color memory
- Two color evaluation channels
- PC programmable via RS232 / USB
- Fibre optic cable with focus lenses
- Detect and allocate colors like the human eye

Principal features:

- Color memory:
8 colors (Teach-In)
255 colors (software)
- RS232/ USB interface
- Bright white light LED
- Perceptive tolerance adjustment using ΔE
- L^*a^*b / L^*u^*v / DIN99 transformation
- Switchable to LED-detection
- Several teach functions (Teach-In / PC / external)
- Difference- / reference- / and 2-channel mode
- FASOP fibre optic cable and focus lenses adaptable
- Logic operation, difference mode
- Switching frequency
up to **15 kHz**
- colorCONTROL LT software

Typical applications:

- Quality management
- Reading and evaluating of RGB color values
- Detection of color rings on metal- and plastic cases
- Detection of color print marks in printing industry
- Color gradient control
- Color variation control
- Color change control
- Color detection and sorting of tins
- Color and grey scale detection
- Packaging control
- Automotive industry (car body panels)
- LED-detection (color and intensity)

Dimensions

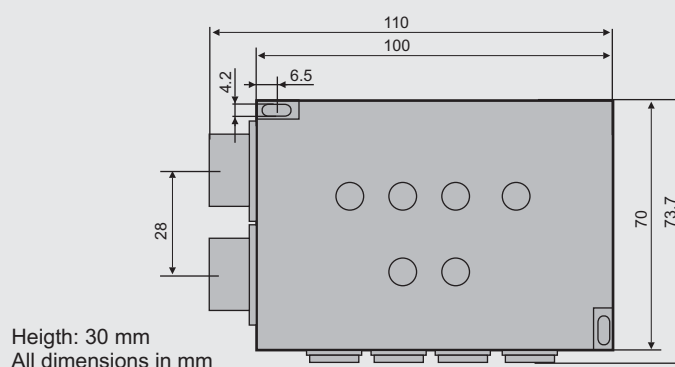

Function

Through one or two fibre optic cable a modulated bright white light LED projects a white light spot onto a surface to be checked. Part of the light that is reflected from the target is directed through the fibre optic cable onto a perceptive True-Color-sensitive detector element. The received light is separated to RGB and transferred into XYZ, L^*a^*b or L^*u^*v . The color sensor can be parameterized (via RS232 or USB) under Windows® with the colorCONTROL LT software. Up to 255 colors can be stored in the sensor. If one of the Teached-In colors is detected, results will be shown at the digital outputs OUT0 to OUT7 of the 8-pin connector.

Ordering information

Product	Part No.
colorCONTROL LT3	10233481
incl. colorCONTROL LT software	
Reference adapter	11233482
Connection cable	
Power supply, length 2 m	11233136
8-pin, Binder / open end	
connection to SPC, length 2 m	11233137
8-pin, Binder / open end	
RS232-cable, length 2 m	11233138
4-pin, Binder / Sub-D 9-pin	
USB-cable, length 2 m	11233139
4-pin, Binder / USB	

Technical data

Electrical data	Supply voltage	9-26 VDC
	Current consumption	typ. 500 mA
	Interfaces	RS232, USB2.0
	Color memory	up to 255 colors with all parameters (2-channel mode: up to 15 colors / channel)
	Signal amplification	1, 5, 25, 100
	A/D conversion	12 Bit per color channel
Measuring value	Switching frequency	up to 15 kHz (> 90 µs)
	Target distance	typ. 1-15 mm (with optical lenses up to 200 mm)
	Color resolution	(L*a*b - mode) $\Delta E_{Lab} \leq 1$
	Relative accuracy at const. ambient conditions	(L*a*b - mode) $\Delta E_{Lab} \leq 1$
	Color spaces	XYZ, L*a*b, L*u*v, DIN 99
Light source	White light LED	color temperature 5500 K
	Brightness	adjustable, can be switched of for self-shining objects
Receiver	3-range color photo diode	Type MTCSi
	Sensitivity	0-8 µW (red channel, 600 nm)
Outputs	OUT 0 to OUT 7	max. 100 mA
	Analogue	A1-A3, 0-10V, max 100 mA
	Interfaces	RS232, max. 115 kBit/s, USB 2.0 Parameter, Color values, Teach-In
	Trigger output	1x trigger output for external light source or for synchronisation with additional sensors
Input	Control input	2x for trigger and synchronization purposes
Data on ambient conditions	Operating temperature	0°C to +50°C
	Ambient light comp.	dynamic, can be switched of for self-shining objects
	Protection	IP54
Housing	Aluminium	black anodized
	Weight	approx. 260 g

Connections

SB2

Pin	Function
1 white	OUT1
2 brown	OUT2
3 green	OUT3
4 yellow	OUT4
5 grey	OUT5
6 pink	OUT6
7 blue	OUT7
8 red	OUT0

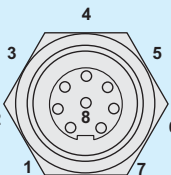
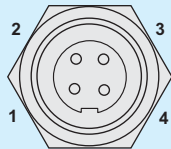

Power supply
Trigger and CLK_OUT
Switching outputs

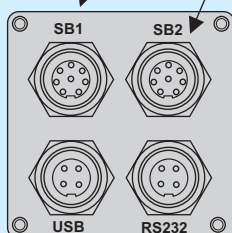

SB1

Pin	Function	Description
1 white	N.C.	
2 brown	N.C.	
3 green	TRG1	INPUT trigger signal for external. synchron. purposes
4 yellow	TRG0	INPUT for updating the sensor outputs (rising edge) in „EXTERN“ mode INPUT for trigger controlled color sequence in „TRIGG.SEQU.“ mode (rising edge) INPUT for starting timed color sequence in „TIMED.SEQU.“ mode (rising edge) INPUT for external triggered Teach-In in „EXT. TEACH“ mode (rising edge)
5 grey	CLK_OUT	OUTPUT signal for synchronization of an additional external light source or an additional sensor
6 pink	N.C.	
7 blue	GND	Ground INPUT
8 red	(+) Vcc	Supply voltage (+9 to 26 V)

RS232

Pin	Function	Pin SUB-D (PC)
1	GND	5
2	TxD	2
3	RxD	3
4	N.C.	

USB

Pin	Function	Standard cable col.
1	GND	black
2	VBUS	red
3	D-	white
4	D+	green



Compact Reflex Color Recognition Sensor

colorCONTROL T1

- 255 color memory
- Teach-In (3 colors)
- PC programmable via RS232
- White light LED illumination

Principal features:

- Working range **30-60 mm**
Spot size approx. **5-13 mm**
- Color memory:
3 colors (Teach-In)
255 colors (software)
- RS232
- Bright white light LED
- Perceptive tolerance adjustment using ΔE
- L^*a^*b / L^*u^*v / DIN99 transformation
- Several teach functions (Teach-In / PC / external)
- Various evaluation algorithms can be activated
- Color grouping
- Sturdy aluminium housing
- Switching frequency
up to **15 kHz**
- colorCONTROL LT software

Typical applications:

- Detection of color rings on metal- and plastic cases
- Reading and evaluating of R G B color values
- Detection of color print marks in printing industry
- Color and grey scale detection
- Color variation control
- Color selection applications (e.g. O-ring seals, closings, crown cap, labels,...)
- Automotive industry (interieur parts)

Dimensions

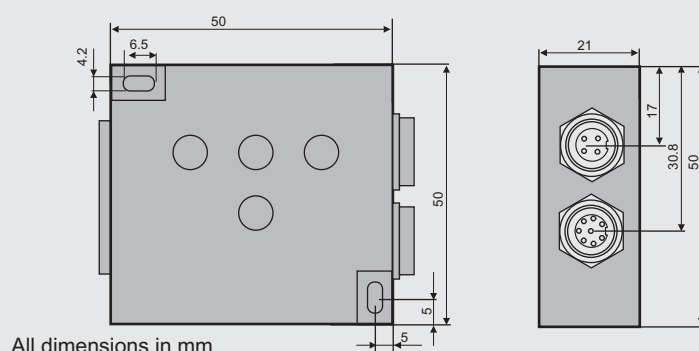

Function

Through an optical transmission unit a modulated white light LED projects a white light spot onto a surface to be checked. Through an optical receiver unit, part of the light that is reflected from the target is then directed onto a perceptive True-Color-sensitive detector element. The received light is separated to RGB and transferred into XYZ, L^*a^*b or L^*u^*v . The color sensor can be parameterized via RS232 under Windows® with the colorCONTROL LT software. Up to 255 colors can be stored in the sensor. If one of the Teached-In colors is detected, results will be shown at the digital outputs CH1 to CH3 of the 8-pin connector.

Ordering information

Product	Part No.
colorCONTROL T1 (colorCONTROL LT software included)	10233480
Connection cable	
Connection SB1, length 2 m 8-pin, Binder / open end	11233136
RS232-cable, length 2 m 4-pin, Binder / Sub-D 9-pin	11233138

Technical Data

Electrical data	Supply voltage	9-26 VDC
	Current consumption	typ. 100 mA
	Interfaces	RS232
	Color memory	up to 255 colors with all parameters (Software)
	Signal amplification	1, 5, 25, 100
	A/D conversion	12 Bit per color channel
Measuring value	Switching frequency	up to 15 kHz (> 90 µs)
	Target distance	typ. 30-60 mm, spot Ø app. 8 mm at 40 mm distance
	Color resolution	(L*a*b - mode) $\Delta E_{Lab} \leq 1$
	Relative accuracy at const. ambient conditions	(L*a*b - mode) $\Delta E_{Lab} \leq 1$
	Color spaces	XYZ, L*a*b, L*u*v, DIN 99
Light source	White light LED	1 W
Receiver	3-range color photo diode	Type MTCSi
Outputs	Digital outputs	CH1-CH3, Push-Pull
	Interfaces	RS232, max. 115 kBit/s Parameter, Color values, Teach-In
	Trigger output	1x trigger output for external light source or for synchronisation with additional sensors
Input	Control input	2x for trigger and synchronization purposes
Data on ambient conditions	Operating temperature	-10°C to +55°C
	Ambient light comp.	dynamic
	Protection	IP54
Housing	Aluminium	black anodized
	Weight	approx. 80 g

Short instruction

Teach colors

- 1 Press SET -button = Setting mode
- 2 Position color and press channel button (eg. CH1) for 2 seconds
- 3 SET- button turns off shortly after 2 sec
- 4 Repeat step 2 and 3 for CH2 and CH3
- 5 Press SET - button to quit the setting mode = SET - button turns off

Tolerance setting

- 1 Press SET -button = Setting mode
- 2 Tolerance setting (channel1) by pressing the CH1 button (blinking frequency indicates the tolerance level)
- 3 Tolerance setting (channel2) by pressing the CH2 button
- 4 Tolerance setting (channel3) by pressing the CH3 button
- 5 Press SET -button to store the tolerance and quit the setting mode.
- 6 SET button turns off after 2 sec.
Blinking frequency: fast (small tolerance)
middle (middle tolerance)
slow (large tolerance)

Delete color and tolerances

Press SET -button for 2 sec.

Light of the channel button indicates the current switching output

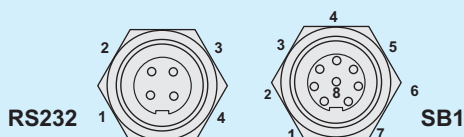

Connections

RS232

Pin	Signal	Pin SUB-D (PC)
1	GND	5
2	TxD	2
3	RxD	3
4	N.C.	do not use

Parameter: 9.600-115.200 baud, Data 8, Parity non, Stop 1

SB1

Pin	Function	Description
1 white	CH1	Output 1
2 brown	CH2	Output 2
3 green	TRG1	INPUT trigger signal for external synchronisation purposes
4 yellow	TRG0	INPUT for updating the sensor outputs (rising edge) in „EXTERN“ mode INPUT for trigger controlled color sequence in „TRIGG.SEQU.“ mode (rising edge) INPUT for starting timed color sequence in „TIMED.SEQU.“ mode (rising edge) INPUT for external triggered Teach-In in „EXT. TEACH“ mode (rising edge)
5 grey	CLK_OUT	OUTPUT signal for synchronization of an additional external light source or sensor
6 pink	CH3	Output 3
7 blue	GND	Ground INPUT
8 red	(+) Vcc	Supply voltage (+9 to 26 V)